

professional projector series

**F32**

WUXGA, 1080p or SXGA+  
up to 6100 ANSI lumens  
24/7 operation warranty  
Fail-safe DuArch™ technology



## Professional projector series

The projectiondesign professional series of projectors include high resolution, high performance products made and conceived especially for graphically challenging applications such as scientific visualisation, motion simulation, medical imaging, and public displays.

As our utmost concern is image quality and operational reliability, all professional series projectors are available with 24/7 operation warranties, and a wide range of configuration options to ensure the best possible application fit and customer satisfaction.

# F32 series

The projectiondesign F32 series of professional grade DLP<sup>®</sup> projectors is our top-of-the line single chip model. It is specifically designed for graphically challenging applications, such as multi channel seamless visualisation walls, domes, and high resolution imaging.

### Markets and applications

With its high performance and wide range of model options, the F32 series is made for tough requirements. Such diverse applications as scientific visualisation and graphics simulation in the technology industries, including medical or chemicals design, physics research and modelling, and oil and gas exploration, are typical applications. But also motion simulators, large public displays in planetariums and museums, and intensive use applications such as process control and NOCs are directly benefitting from the F32 series features.

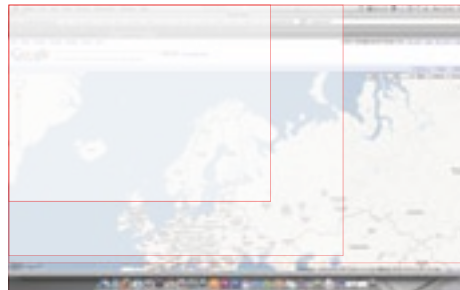

WUXGA resolution relative to 1080p, SXGA+, and XGA.

### High resolution

The F32 series features WUXGA, 1080p, or SXGA+ resolution options for optimum application fit. Whether computer graphics or video centric, wide screen or legacy 4:3, there is a model with the right resolution available. In fact, with this range of resolutions, the series covers nearly any need and requirement in virtually any professional AV market.

### DLP technology – chosen for reliability

The DLP technology from Texas Instruments<sup>®</sup> is chosen for its unmatched reliability performance, and its unique coupling with long lasting image quality. With a widely recognized and proven reliability record, and high brightness and contrast, all whilst displaying utterly natural colours, it is the obvious choice for heavy duty applications, applications that are that run continuously, or are mission critical. Independent testing has proven DLP technology to be the most reliable of all microdisplays; not degrading when subjected to UV light, inherent in all projectors. Unlike competing technologies, showing severe image quality degradation after only a few thousand hours, DLP technology remains constant over hundreds of thousands of hours.

*The Expo Zaragoza exhibition features a large number of projectiondesign projectors, chosen for a combination of performance and reliability*





### Designed for full 24/7 operation

All projectiondesign professional projectors feature full 24/7 operation warranties. That means they are designed to operate continuously. There is no fine print. Designing for 24/7 operation requires a lot of attention to detail. Some technologies are better than others when it comes to withstand the abuse of time. We use only components that have predictable behaviours, for instance fans, colour wheel motors, and electronic components that are designed by their respective manufacturers to do the same - withstand time. There are no off-the-shelf components. That is why we also closely monitor the creation of every detail, apply dedicated thermal management, and use specific materials in all parts of the process.



### Image quality

A key focus point in the development of the new F32 series is image quality. Every single projector model can, unlike most of its competitors, be calibrated to exacting colour standards, coupled with a desired brightness and contrast. By enabling this, users are certain that what they see on screen, whether video or computer graphic, is real. Deeply saturated colours and high contrast are key to achieving this.

### Intelligent and active cooling

The F32 series features intelligently adaptive and active cooling of the entire system. Adapting cooling actively to the environment, and the ambient temperature not only reduces acoustic operating noise, but more importantly increases reliability and longevity by having much tighter control over all vital functions in the projector itself. Using the thermo-electric cooling principle, power is applied to actively cool key elements throughout the projector.

*All projectiondesign projectors are built and designed from ground up to make sure they are exactly what we want them to be.*



# RealColor™ colour management

RealColor is projectiondesign's unique colour management calibration suite. Each F32 projector is uniquely characterised during its manufacture. Unique performance values and characteristics are recorded and matched to the electronics processing in order to secure perfect on-site calibration. With RealColor, it is possible to match any number of projectors, and ensure they all project the same primaries and grey scale, without going through a very complicated process.



## What RealColor gives

RealColor provides a unique and quick way to calibrate and set up perfect images for any number of projectors. RealColor can alter imagery by changing simple characteristics such as the colour temperature of the image – perfectly along the black body curve, or very complex things such as each colour's relative saturation and x/y coordinates. In fact, it is perfect to within 0.001 along all axes of measurement. RealColor works by mathematically calculating each colour independently.

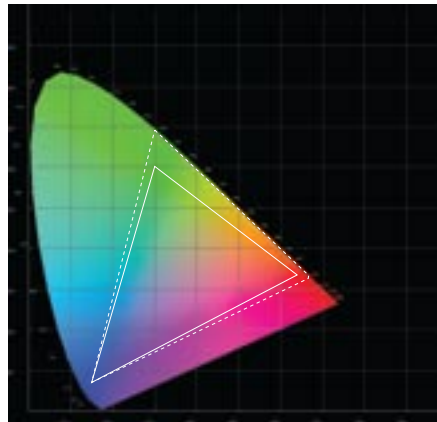

▲ Different color wheels have different color characteristics.

## VIDI™ lamp technology

New VIDI technology from Philips enables dynamic lamp driving over time, and greatly enhances image quality. It reduces grey scale artefacts, adds to colour saturation, enhances contrast, and improves lamp stability. Each projector configuration's lamp runs differently from that of others, and ensures a lamp that is specifically tailored to the application it is used for. Unlike non-VIDI lamps and operation, the lamp power is digitally controlled, as is its performance over time.

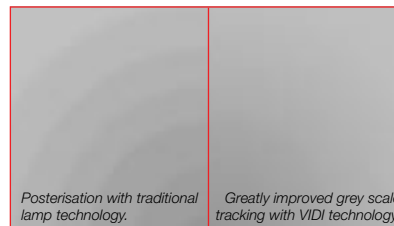

## Colour wheel options

Each F32 can be configured with a range of colour wheel options, either High Brightness, Graphics, or VzSim. Each have unique characteristics. VizSim focuses on colour quality, low colour cross talk and contamination, and reduced artefacting. The Graphics version gives lower saturation, but higher brightness for general AV use, and the High Brightness option gives a high brightness with great colours. All options are greatly superior to standard "three colours plus clear" segment in all performance aspects.

## BrilliantColor™ changes what you see

Adding to the performance of the F32 series is Texas Instruments' BrilliantColor™ colour processing. By using six colour processing, brightness, colour saturation, and dynamics are greatly enhanced. Where needed, the secondary colours cyan, magenta, and yellow are boosted, but if desired, can be totally omitted for a pure primary colour system with low cross-colour distortion and cross talk.

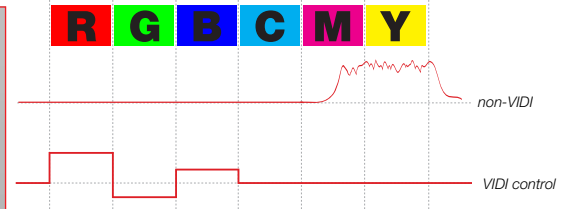

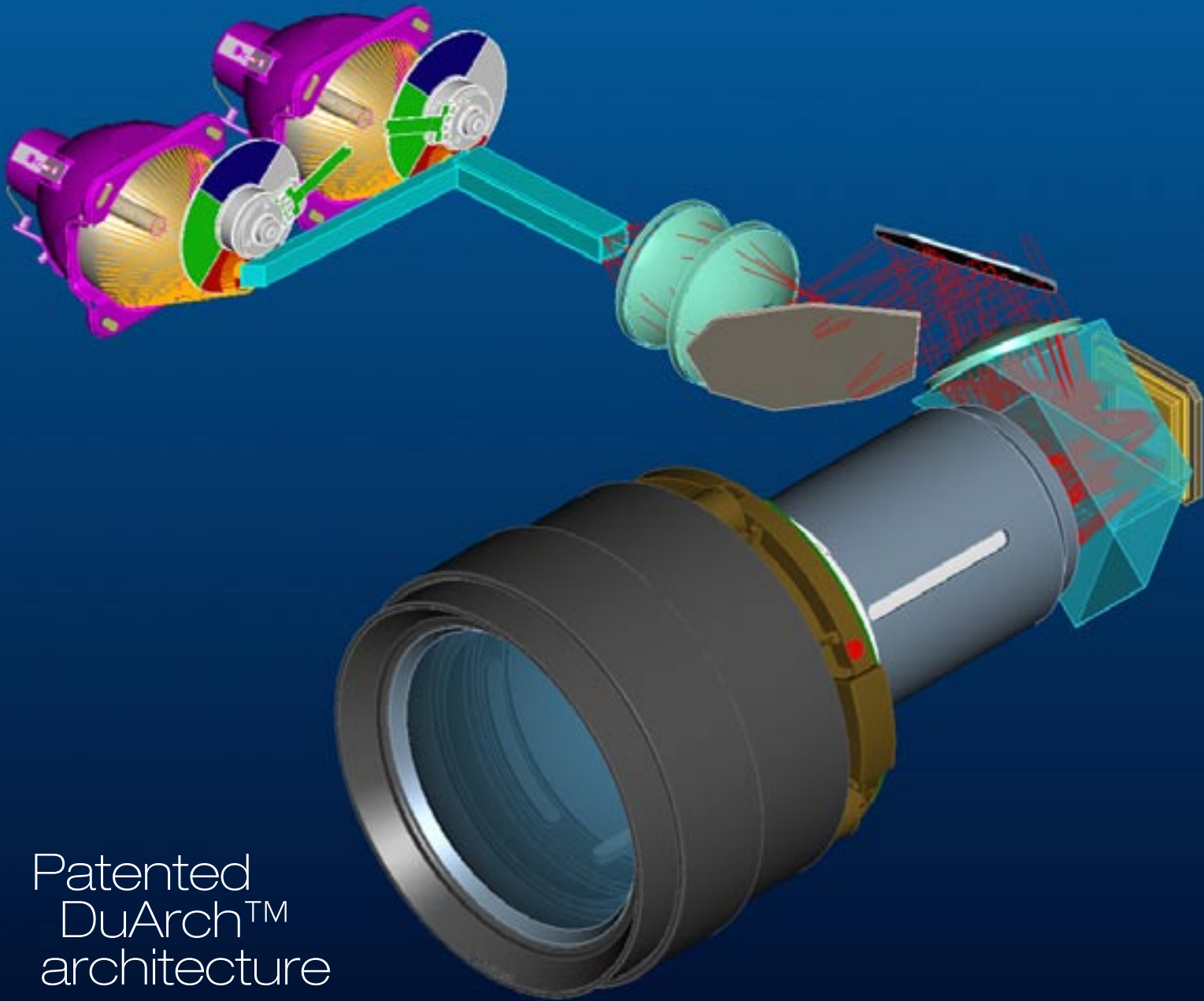

## Patented DuArch™ architecture

The F32 projectors use our patented DuArch™ Dual Illumination architecture. DuArch increases brightness and performance from an optical system by utilising two lamps, two colour wheels, and two complete sets of illumination optics. Additionally, the DuArch optical architecture in the F32 series allows hot swapping of lamps, meaning one lamp can be replaced while the other is still running, enabling true 24/7 operation, without the need to turn off the projector to change lamps. Unlike some competition, both lamps are individually powered, and mechanically disconnected from each other.

### High resolution lenses

All projectiondesign projection lenses and optics are made purely from glass, and utilise Low Dispersion (LD) glass and aspherical elements to ensure the best possible sharpness and focus over the entire image. Using very high quality lenses also ensures high contrast, and extremely low colour aberration, and flare. This, in effect, is a key element of the incredibly high performance of each F32 projector.

### Sealed Optical Architecture

The F32's sealed optical architecture ensures trouble-free operation in unforgiving and harsh environments, such as process control environments and public places. Dust, smoke and tiny particles are prevented from entering and contaminating the light engine, thus will not alter the displayed image or quality over time. In addition, it ensures the projector requires virtually no servicing or maintenance.

### Designed for multi-channel systems

With the unique colour matching and calibration tools in RealColor, the F32 is virtually made for matching of images, edge blending and multi-channel installations, whether the process is done electronically in software, or by using hardware solutions. Very deep black levels and both black and white level uniformity, add to the impressive performance.

## Total Cost of Ownership

For professional projectors, the Total Cost of Ownership is rarely only related to the cost of the projector itself, and a lamp or two. projectiondesign develop projectors from ground up with this in mind, and both the environmental cost – in form of high image performance per watt, and the actual monetary cost of owning a projector, are low. Very often, the real cost of owning projectors are hidden in service and maintenance agreements. With the F32 series, several product features contribute to low maintenance costs.

### Low Total Cost of Ownership

Thanks to its complex and very robust build and construction, the F32 series requires very little maintenance and in-life servicing. In fact, there are no user serviceable parts inside, and it does not have any filters or other parts that need periodical replacement. That means it does not require a costly and high frequency maintenance contract. Similarly, and compared to similarly performing Xenon high power lamps, lamp replacement cost is low<sup>1</sup>, and typical lamp life is long. In total, a very cost effective projector over time, resulting in a very low cost of ownership.

<sup>1</sup> When replacing lamps, it is key to use only original parts and accessories, as aftermarket lamps may reduce performance, and damage the projector.



▲ Original VDI lamp with projectiondesign optimised fixture mechanics.

### Low Frequency Maintenance programme

Our Low Frequency Maintenance programme can be set to automatically notify of required service and maintenance. When run continuously, moving parts such as fans and colour wheels require periodic replacement in order to secure and enable heavy duty, and continuous operation. With the F32, the shortest duty cycle of any one component – run in full power mode, is as long as 8000 hours, meaning a full year's operation in 24/7 without any maintenance. Add hot swappable lamps to that, and you have a projector simply does not need to be turned off.





▲ User replaceable, and hot swappable lamp compartments are part of the DuArch™ Dual Illumination Architecture.

### Upgradeable features

Every single F32 projector, no matter what configuration, can quickly and easily be upgraded through downloadable softwares and updates. This ensures each model is always up to date with new features, available performance enhancements, and potential fixes of non-conforming operation. Like modern computers, all is freely available from our web site, and can be performed by anyone.

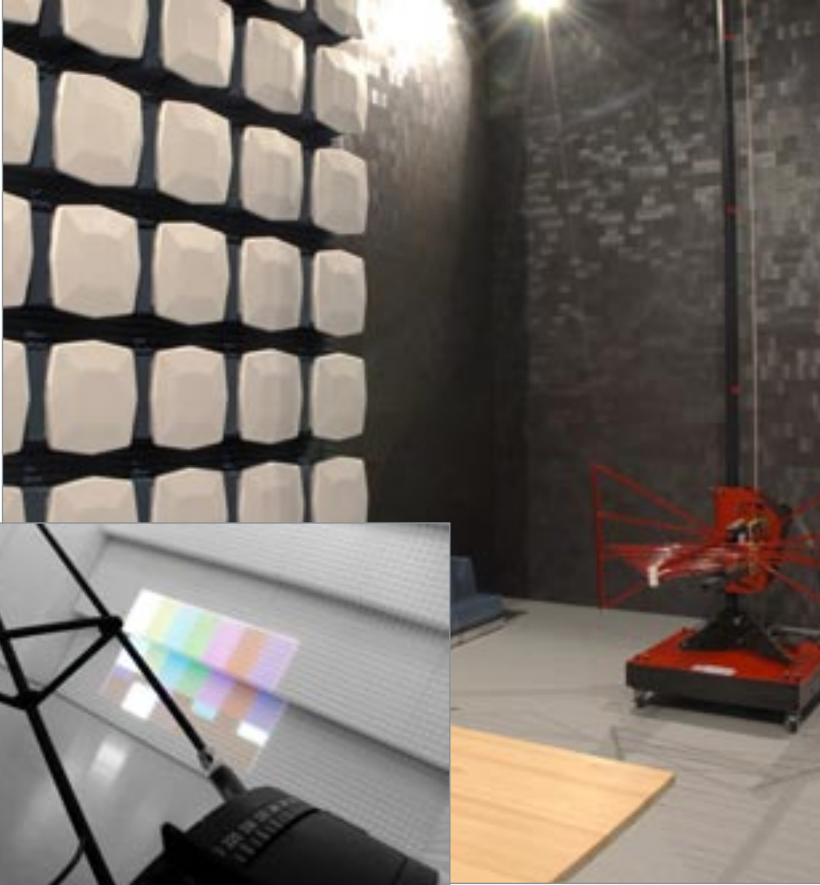



 projectiondesign in-house EMC lab.  
 In-house acoustics lab.

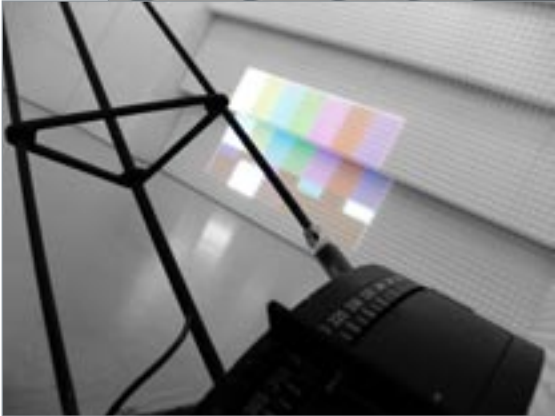

# Immaculate process management

Every single F32 projector is rigorously tested, and characterised in-house. We keep test records and performance statistics for every single unit. Also, as we put our pride into making great projectors, they are not passed down an automated production line, but enjoy the careful management of people at all stages of their manufacture. That also means we are personally responsible for all of them. In addition, every single projector is made to specific order. That means that the configuration ordered is the configuration built, and only existing in that particular installation.

## In house development and process management

Every single part of the F32 series projectors is developed, rigorously tested, and verified in-house at projectiondesign. With more than 800 models and variations of projectors in regular manufacturing, testing facilities include everything from acoustical analysis labs, to a full featured FCC Class EMC lab, environmental labs for lifetime and operational testing, as well as our own optics labs and various test and demo labs.

## ProNet Asset Management

Adding to the serviceability and in-life monitoring features, the projectiondesign ProNet.Manager asset management suite can be set up to monitor and report on an unlimited number of projectors in a dedicated or corporate network, in a single site, or in multiple sites. ProNet monitors every single aspect of the projector, from individual lamp and fan statuses, to operating hours, usage statistics, and

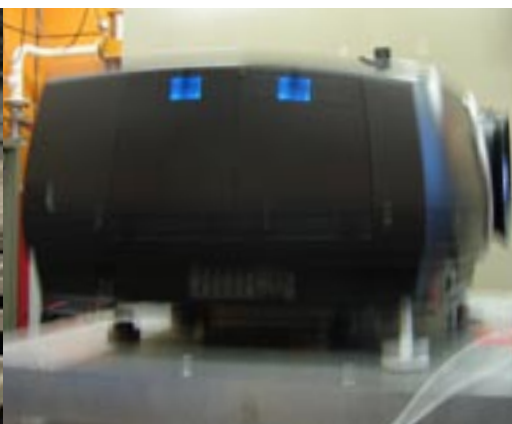
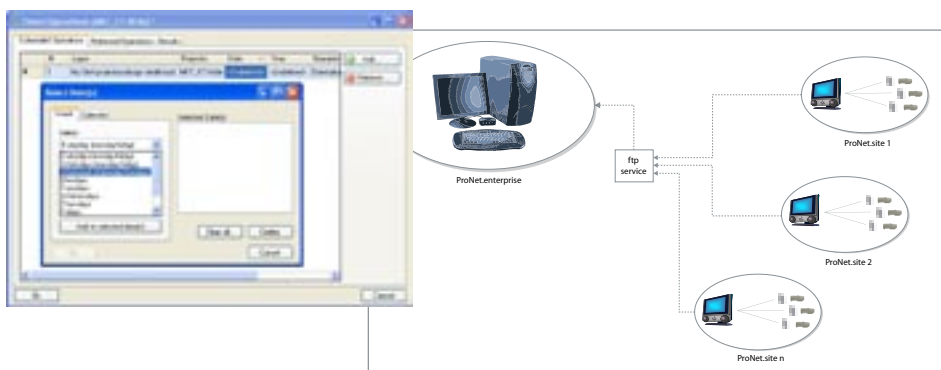

Technical specifications

<b>projector</b>	DLP® digital projector		
<b>display</b>	technology	single chip DMD™ (Digital Micromirror Device™)	
	concept	sealed, all-glass optical design with lens shift	
	available resolutions	1920 x 1200	1920 x 1080 1400 x 1050
	brightness	High Brightness	5700 5700 6100
		Graphics	3800 3800 4100
		VizSim	2900 2900 3100
	contrast ratio	up to 7500 : 1 (on/off)	
	colours	30-bit	
	colour management accuracy	± 0.01 on x, y, z axis	
	image processing latency	~ 22 ms on graphics port	
<b>input signal compatibility</b>	computer	up to 1920 x 1200 pixels	
		RGBHV, RGBS, RGB	
	horizontal scan frequency	15 - 150 kHz	
	vertical scan frequency	48 - 190 Hz	
	video	HDTV (1080i, 720p, 576i/p, 480i/p)	
		NTSC 3.58/4.43, PAL, BGHI, M, N, SECAM	
	bandwidth	205 MHz analog RGB	
		165 MHz digital RGB (DM or HDMI)	
<b>optics</b>	available lenses	fixed focal ultra wide angle	EN12 (503-0057-00)
		fixed focal wide angle	EN15 (503-0060-00)
		wide angle zoom	EN13 (503-0058-00)
		standard zoom	EN11 (503-0056-00)
		short tele zoom	EN14 (503-0059-00)
		long tele zoom	EN16 (503-0061-00)
	focusing distance	0.5 - 40m (see separate lens specifications)	
	optical lens shift	vertical and horizontal	
		EN12 on axis only	
	lens iris control	f/2.1 - 6.5 for all lenses, continuously adjustable	
	shutter	mechanical	
	colour wheel options	ROBRGB - visualization & simulation	
		RGBCMY - graphics display	
		RGBCYW - high brightness display	
	lamp	2 x 300W UHP™	
	lamp life	2000 hrs (5000 hrs in eco relay mode)	
	replacement lamp part no.	400-0500-00	

<b>connectivity</b>	computer	1x HDMI (1.3)
		1x DVI-D
		1x 15-pin DSub
		1x BNC x5
	video	1x HDMI (v1.3) (HDCP)
		1x DVI-D (HDCP)
		1x RCA x3 YUV
		1x 4-pin mini DIN Y/C
		1x RCA composite video
	control and communication	1x RJ45 TCP/IP network port
		2x RS232 9-pin DSub (in / out)
		1x USB - mouse control & firmware upgrade
		2x 12V (60mA) triggers (screen drop / aspect)
		1x RC repeater, 3.5mm mini jack
	other	2x configurable XPort™ (front- / back end)
<b>supplied accessories</b>	cables	4m power cord (country dependant)
	other	backlit IR remote control, ceiling mount cable cover
<b>general</b>	product documentation	product documentation
	dimensions (dwh)	376 x 510 x 223 mm (exc. lens)
	weight	about 12.6 kg (exc. lens)
	environmental	RoHS, WEEE
	security	4-digit PIN code, Kensington lock
	power requirements	100 - 240 VAC, 50/60 Hz, +/- 10%
		<1050W power consumption
	BTU/hr	<2900
	conformances	CE, CSA "C/US", FCC Class A, CCC
	operating temperature	0 - 40°C / 32 - 104°F; 0 - 1500 m
		0 - 35°C / 32 - 95°F; 1500 - 3000 m
	operating and storage	20 - 90% RH
	available colours	black metallic, silver metallic
	warranties	2 years, 24/7, 500 hours or 90 days on lamp
		Up to 5 years total extended warranty available. Conditions apply.



Standardised bolt-on ceiling mount interface

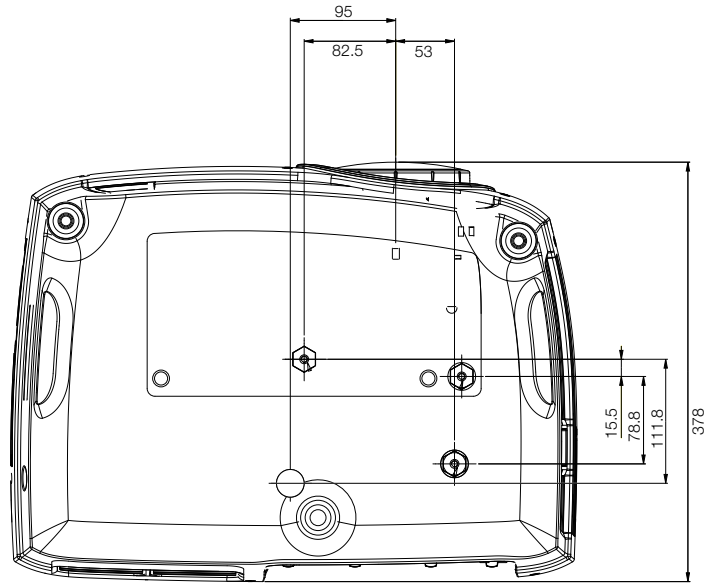
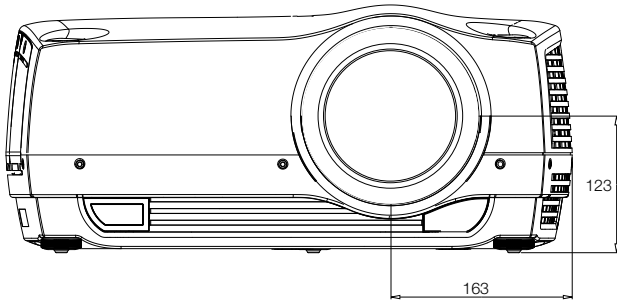

Wide range of projection lenses

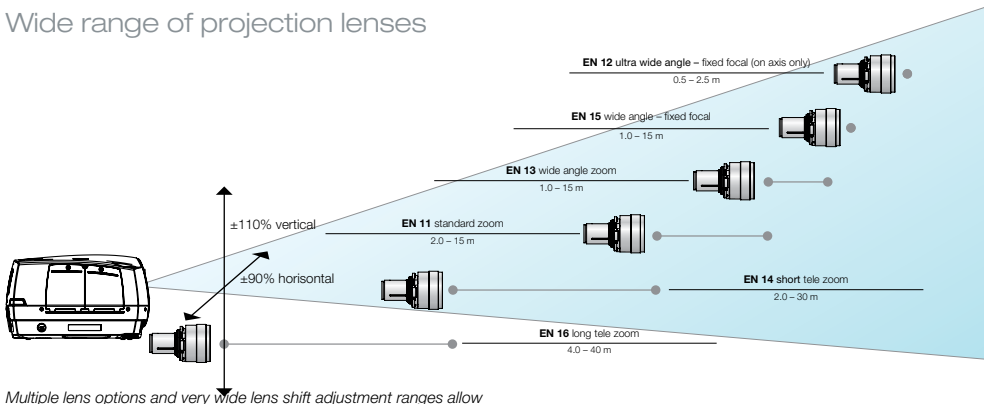

Rotation

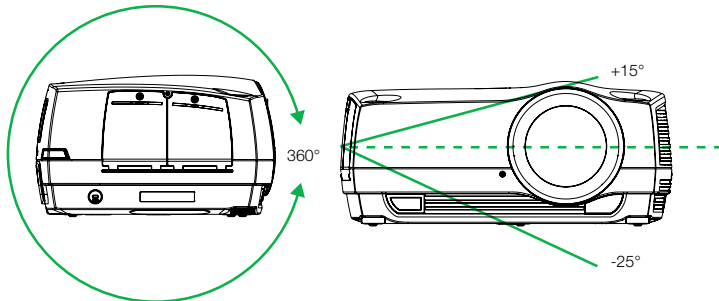

The F32 can be rotated 360 degrees around the side to side axis, and for instance project straight down or up, as well as +25/-15 degrees side to side.

Throw ratios

	WUXGA	1080p	sxga+
ultra wide angle	0.79	0.79	0.84
wide angle	1.16	1.16	1.25
wide angle zoom	1.24 - 1.60	1.24 - 1.60	1.34 - 1.74
standard zoom	1.60 - 2.32	1.60 - 2.32	1.74 - 2.51
short tele zoom	2.37 - 3.79	2.37 - 3.79	2.56 - 4.10
long tele zoom	3.80 - 6.50	3.80 - 6.50	4.10 - 7.10
± 5% accuracy			

Available versions

Resolution	Colour Wheel	VizSim	Graphics	High Brightness
WUXGA		101-1427-xx	101-1428-xx	101-1429-xx
1080		101-1424-xx	101-1425-xx	101-1426-xx
SX+		101-1430-xx	101-1431-xx	101-1432-xx
Available colours: -08 Black Metallic, -14 Silver Metallic				

head office

projectiondesign as  
 Habornveien 53  
 N-1630 Gamle Fredrikstad, Norway  
 ph +47 69 30 45 50  
 fx +47 69 30 45 80  
 sales@projectiondesign.com

regional offices

the Americas  
 projectiondesign LLC  
 295 North Street,  
 Teterboro, NJ 07608, USA  
 ph +1 888 588 1024  
 fx +1 201 288 1034  
 americas\_sales@projectiondesign.com

Sweden  
 projectiondesign as  
 Göteborg, Sweden  
 ph +47 69 30 45 50  
 fx +47 69 30 45 80  
 sweden\_sales@projectiondesign.com

Germany, Austria, Switzerland  
 projectiondesign as  
 Stuttgart  
 ph +49 7153 958263  
 mo +49 (176) 2316 0345  
 fx +47 69 30 45 80  
 germany\_sales@projectiondesign.com

Southern Europe  
 projectiondesign as  
 Via Plinio 43, I-20129 Milano (MI), Italy  
 ph +39 02 45471864  
 fx +39 02 45471865  
 southe\_sales@projectiondesign.com

BeNeLux  
 projectiondesign as  
 J. A. L. J. van Meertenstraat 4  
 4194WL Meteren, The Netherlands  
 ph +31 (0) 345753314  
 fx +31 (0) 345753314  
 benelux\_sales@projectiondesign.com

United Kingdom  
 projectiondesign as  
 Regus House, Herons Way, Chester Business Park,  
 Chester, CH4 9QR, United Kingdom  
 ph +44 (0)1244 893 231  
 fx +47 69 30 45 80  
 uk\_sales@projectiondesign.com

Asia  
 projectiondesign as  
 161 Kallang Way,  
 #04-05 Kolam Ayer Industrial Estate, Singapore 349247  
 ph +65 9621 7421  
 fx +47 69 30 45 80  
 asia\_sales@projectiondesign.com

Spain and Portugal  
 projectiondesign as  
 Gorrondaxe15, bajo A  
 48640 Berango, Spain  
 ph 34 676 266 301  
 fx +47 69 30 45 80  
 iberica\_sales@projectiondesign.com

India, including SAARC  
 projectiondesign as  
 Mumbai  
 ph +91 982 061 0670  
 fx +47 69 30 45 80  
 india\_sales@projectiondesign.com

South Africa, Africa, Middle East and Oceania  
 projectiondesign as  
 1 Peterhof Close  
 Hout Bay 7806, South Africa  
 ph + 27 21 79 00 018  
 fx +47 69 30 45 80  
 africa\_sales@projectiondesign.com  
 oceania\_sales@projectiondesign.com



Distributed by: